

BODYWORX

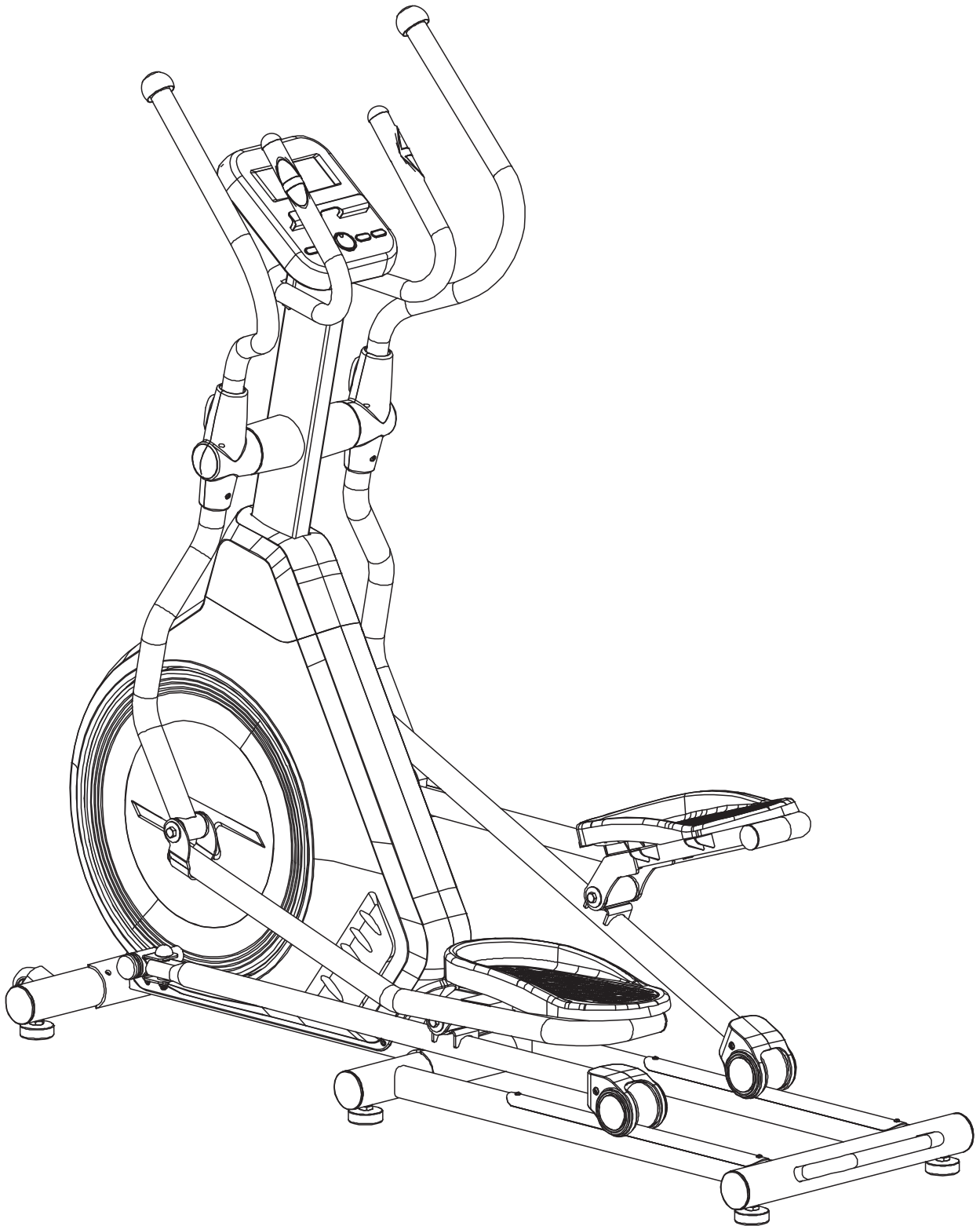

PROGRAMMABLE ELLIPTICAL

Model No: EFX580



Retain this owner's manual for future reference. Read and follow all instructions in this owner's manual.



Warranty Registration Form

Congratulations on purchasing your product, we at GPI believe that our product range is of the highest quality and represents great value for money.

We back our product range up with our industry leading warranty.

Please see below for the step by step instructions on how to register your product warranty online.



Step 1 Visit our Website

Go to the GPI Sports website: www.gpisports.com.au/warranty



Step 2 Enter Purchase Information

Enter all purchase information including the serial number and proof of purchase which can be uploaded from this page



Step 3 Call Our Toll Free Number

If a warranty service request is required on your product please call the toll free number - **1800 005 770**

CONTENTS PAGE

IMPORTANT SAFETY INSTRUCTIONS	4
SAFETY GUIDELINES	5
EXERCISE INSTRUCTION	6-7
HARDWARE PACK	8
ASSEMBLY INSTRUCTIONS	9-14
CONSOLE INSTRUCTIONS	15-18
MAINTENANCE	19
EXPLODED DIAGRAM	20-21
PART LIST	22-25

IMPORTANT SAFETY INSTRUCTIONS

Before beginning any fitness program, you should obtain a complete physical examination from your physician.

This exercise equipment is designed and built for optimum safety for home use. However, certain precautions always apply whenever you operate any exercise equipment. Be sure to read the entire manual before assembly and operation of this machine. Also, please note the following safety precautions.

WHEN USING EXERCISE EQUIPMENT, YOU SHOULD ALWAYS TAKE BASIC PRECAUTIONS INCLUDING THE FOLLOWING:

- Read all instructions before using the machine. These instructions are written to ensure your safety and to protect the unit.
- Do not allow children on or near the equipment.
- Use the equipment only for its intended purpose as described in this guide.
- Do not use accessory attachments that are not recommended by the manufacturer. Such attachments might cause injuries.
- Wear appropriate exercise clothing and shoes for your workout, no loose clothing. Do not wear shoes with heels or leather soles. Ensure shoes are clean of dirt and embedded stones.
- Use care when getting on or off the unit.
- Do not over exert yourself or work to exhaustion.
- If you feel any pain or abnormal symptoms, stop your workout immediately and consult your physician.
- Never operate the unit after it has been dropped or damaged. Return the equipment to a service center for examination and repair.
- Never drop or insert objects into any opening in the equipment.
- Always check the unit before each use. Make sure that all fasteners are secure and in good working condition.
- Do not use the equipment outdoors or near water.
- Only one person may use the machine at a time.

CHILDREN AND PETS

- Most exercise equipment is not recommended for small children. Children should not use the equipment unless they are under strict adult supervision. To ensure safety, keep young children off the machine at all times.
- Exercise equipment has many moving parts. In the interest of safety, keep others (especially children and pets) at a safe distance while you exercise.

PERSONAL SAFETY DURING ASSEMBLY

- It is strongly recommended that a qualified dealer assemble the equipment. Assistance is required.
- Before beginning assembly, please take the time to read the instructions thoroughly.
- Read each step in the assembly instructions and follow the steps in sequence. Do not skip ahead. If you skip ahead, you may learn later that you have to disassemble components and that you may have damaged the equipment.
- Assemble and operate the machine on a solid, level surface. Locate the unit at least 1 meter from the walls or furniture to provide easy access.

The machine is designed for your enjoyment. By following these precautions and using common sense, you will have many safe and pleasurable hours of healthy exercise.

After assembly, you should check all functions to ensure correct operation. If you experience problems, first recheck the assembly instructions to locate any possible errors made during assembly.

Maximum User Weight: 120 KG

SAFETY GUIDELINES

Successful fitness training programs have one prominent feature in common...safety. Fitness training has some inherent dangers, as do all physical activities. The chance of injury can be greatly reduced or completely removed by using correct techniques, proper breathing, maintaining equipment in good working condition, and by wearing the appropriate clothing.

- It is highly recommended that you consult your physician before beginning any exercise program. This is especially important for individuals over the age of 35, or persons with pre-existing health problems.
- Always warm up before starting a workout. Try to do a total body warm up before you start.
- Maintaining equipment in proper operating condition is of utmost importance for a safe training program.
- Keep hands, limbs, loose clothing and long hair well out of the way of all moving parts.
- Inspect the machine before each use for loose or worn parts. Ensure all nuts and bolts are fully tightened. If a problem is found do not allow the machine to be used until all parts are tightened or worn or defective parts are repaired or replaced.

EXERCISE INSTRUCTIONS

Using your exerciser will provide you with several benefits, it will improve your physical fitness, tone muscle and in conjunction with a calorie controlled diet help you lose weight.

1. THE WARM UP PHASE

This stage helps get the blood flowing around the body and the muscles working properly. It will also reduce the risk of cramp and muscle injury. It is advisable to do a few stretching exercises as shown below. Each stretch should be held for approximately 30 seconds, do not force or jerk your muscles into a stretch - if it hurts, **STOP**.

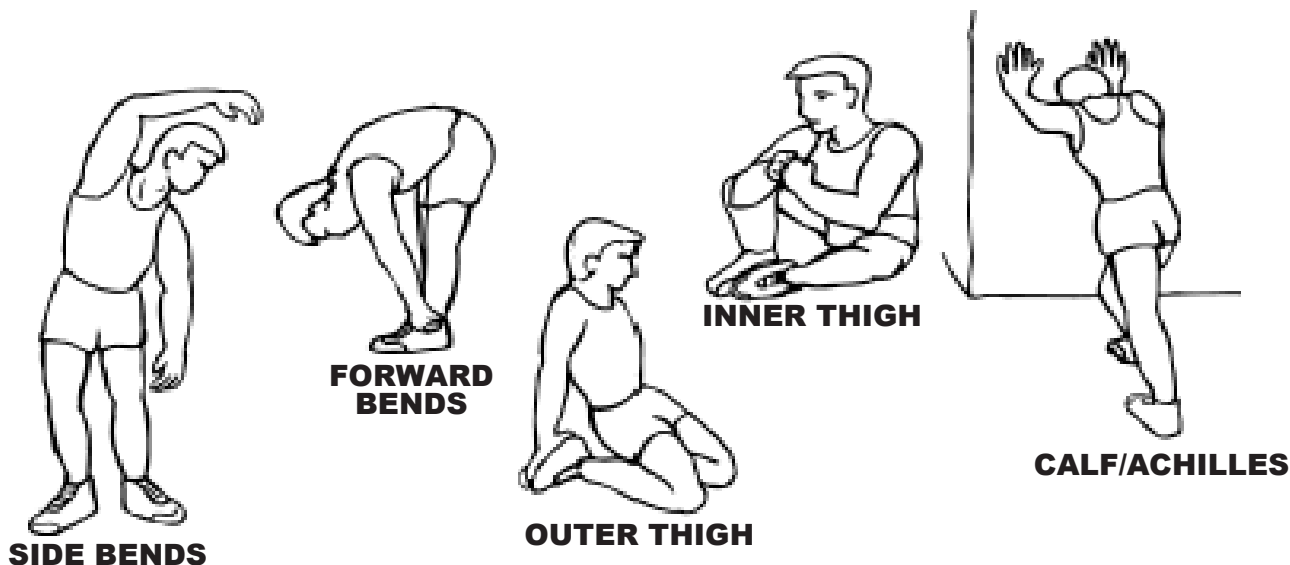

2. THE EXERCISE PHASE

This is the stage where you put the effort in. After regular use, your muscles will become more flexible. Work to your own level but it is very important to maintain a steady tempo throughout. The rate of work should be sufficient to raise your heart beat into the target zone shown on the graph below.

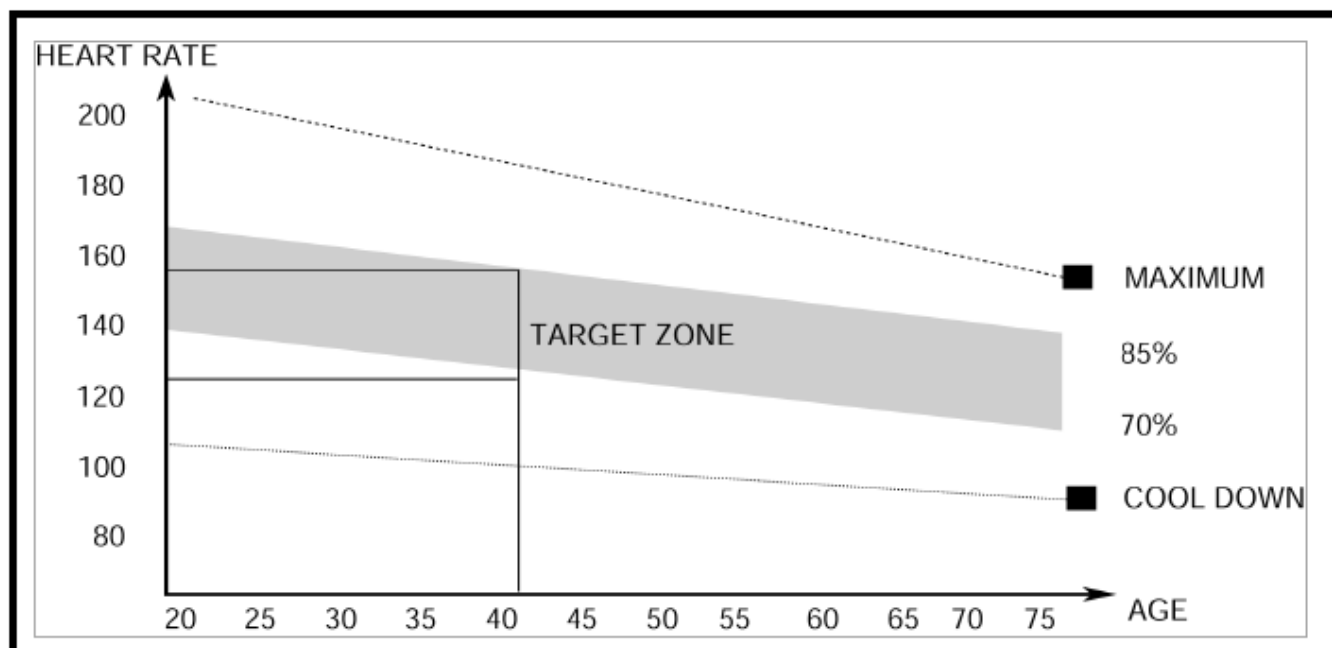

This stage should last for a minimum of 12 minutes though most people start at about 15-20 minutes.

EXERCISE INSTRUCTIONS

3. THE COOL DOWN PHASE

This stage is to let your Cardio Vascular System and muscles wind down. This is a repeat of the warm up exercise e.g. reduce your tempo, continue for approximately 5 minutes. The stretching exercises should now be repeated, again remembering not to force or jerk your muscles into the stretch.

As you get fitter you may need to train longer and harder. It is advisable to train at least three times a week, and if possible space your workouts evenly throughout the week.

MUSCLE TONING

To tone muscle while on your exerciser you will need to have the resistance set quite high. This will put more strain on your muscles and may mean you cannot train for as long as you would like. If you are also trying to improve your fitness you need to alter your training program. You should train as normal during the warm up and cool down phases, but towards the end of the exercise phase you should increase resistance, making you work harder. You may have to reduce your tempo to keep your heart rate in the target zone.

WEIGHT LOSS

The important factor here is the amount of effort you put in. The harder and longer you work the more calories you will burn. Effectively this is the same as if you were training to improve your fitness, the difference is the goal. The calorie function, where applicable, is an estimate only and to be used for comparison between workouts.

CARE AND MAINTENANCE

Proper maintenance is very important to ensure your equipment is always in top working condition. Improper maintenance could cause damage or shorten the life of your equipment and void the WARRANTY coverage

Important: Never use abrasives or solvents to clean the equipment. To prevent damage to the computer, keep liquids away and keep it out of direct sunlight.

After each workout: Wipe off the console, where applicable, and other frame surfaces with a clean, water dampened soft cloth to remove excess perspiration. Inspect and tighten all parts of the equipment regularly. Replace any worn parts immediately.

Don't use the equipment before the worn parts were replaced by new ones. When you feel the exerciser is not smooth, please check the status of the parts and if need be call the service hot line.

HARDWARE PACK

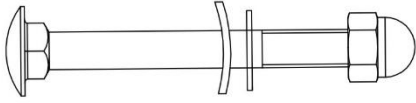

(51) Bolt M8x80 2PCS
 (43) Curve Washer $\Phi 8 \times \Phi 20 \times 2.0$ 2PCS
 (32) Spring Washer $\Phi 8$ 2PCS
 (29) Cap Nut M8 2PCS

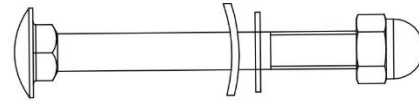

(42) Bolt M8x75 2PCS
 (43) Curve Washer $\Phi 8 \times \Phi 20 \times 2.0$ 2PCS
 (32) Spring Washer $\Phi 8$ 2PCS
 (29) Cap Nut M8 2PCS

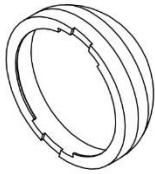

(30) Cap Nut S38
 2PCS

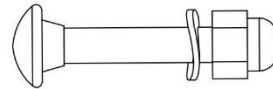

(28) Bolt M8x49 4PCS
 (20) Curve Washer $\Phi 8 \times \Phi 16$ 4PCS
 (29) Cap Nut M8 4PCS

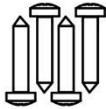

(52) Self-tapping screw ST4.2*20
 4PCS



(69) Screw ST2.9*16
 4PCS

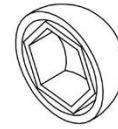

(65) Cap Nut S13
 2PCS



Allen Wrench 6mm
 1PC

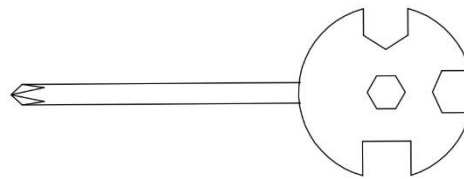

Multi Hex Tool/Phillips Screwdriver
 S10, S13, S14, S15
 1PC

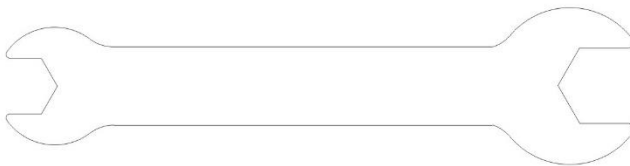

Solid Wrench
 S14- S19
 2PCS

ASSEMBLY INSTRUCTIONS

STEP 1.

#44	X6
	

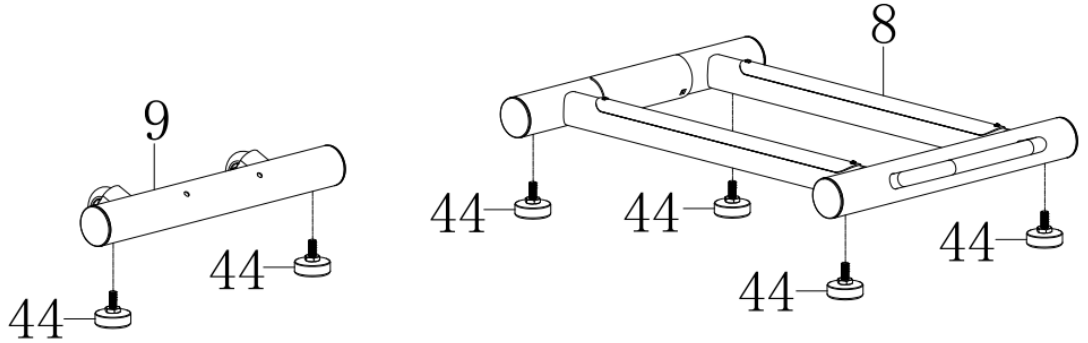

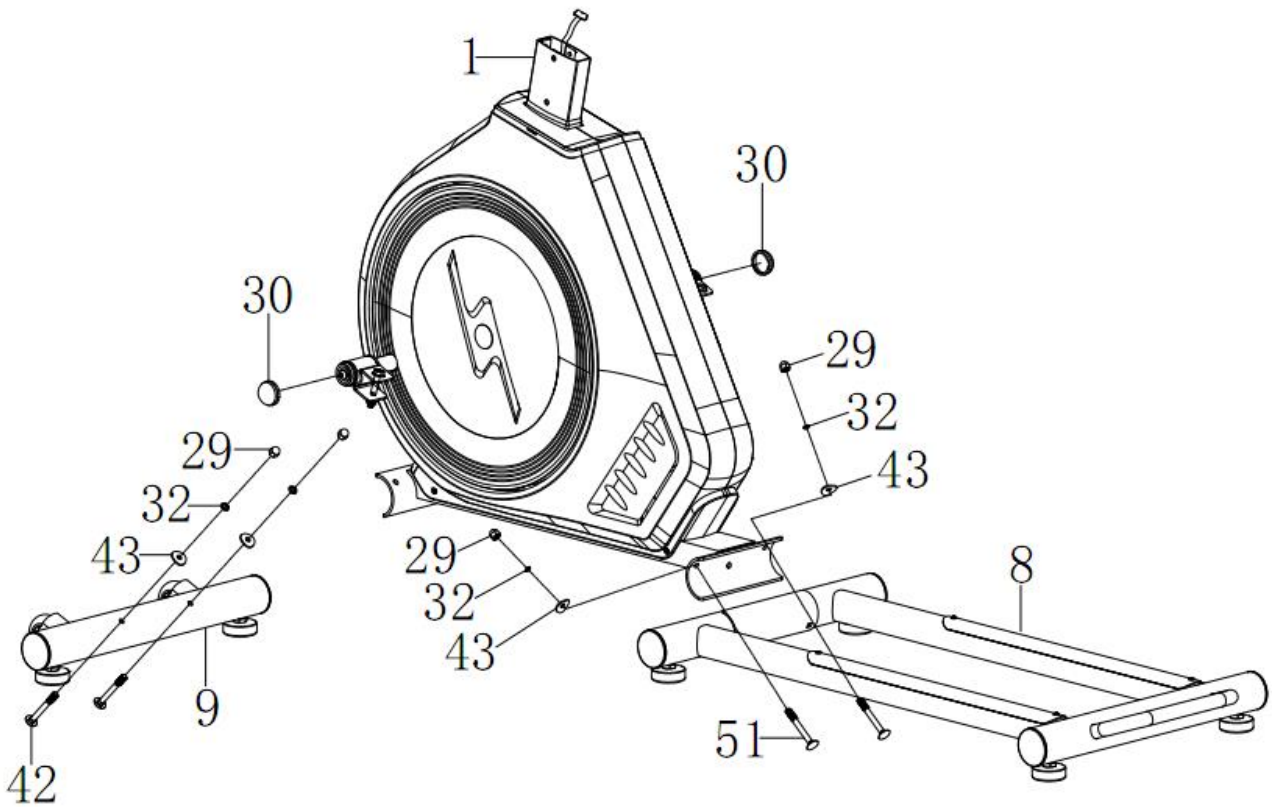

STEP 2.

#42	#43	#32	#29	X2	#51	#43	#32	#29	X2
									





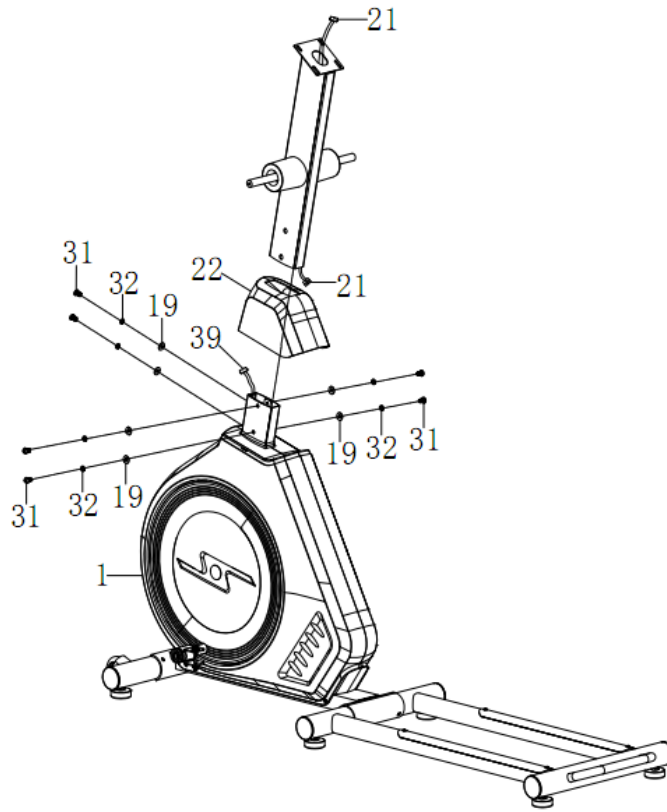

ASSEMBLY INSTRUCTIONS

STEP 3.

#31	#32	#19	X6
			



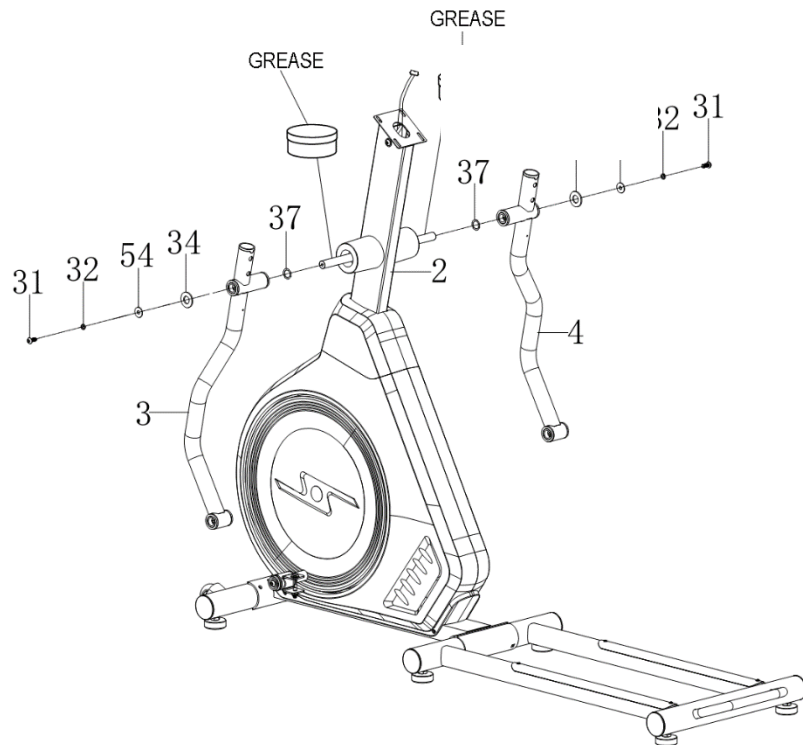

STEP 4.

#31	#32	#54	#34	#37	X2
					





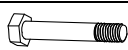

ASSEMBLY INSTRUCTIONS

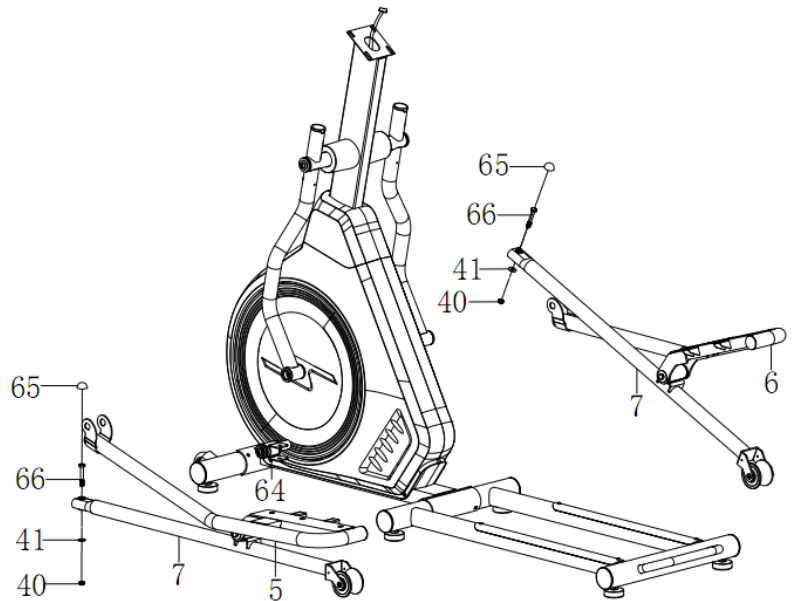
STEP 5.

#65	#66	#41	#40	X2
				

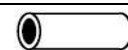

STEP 6.

#23	#54	#68	#54	#23	X2
					

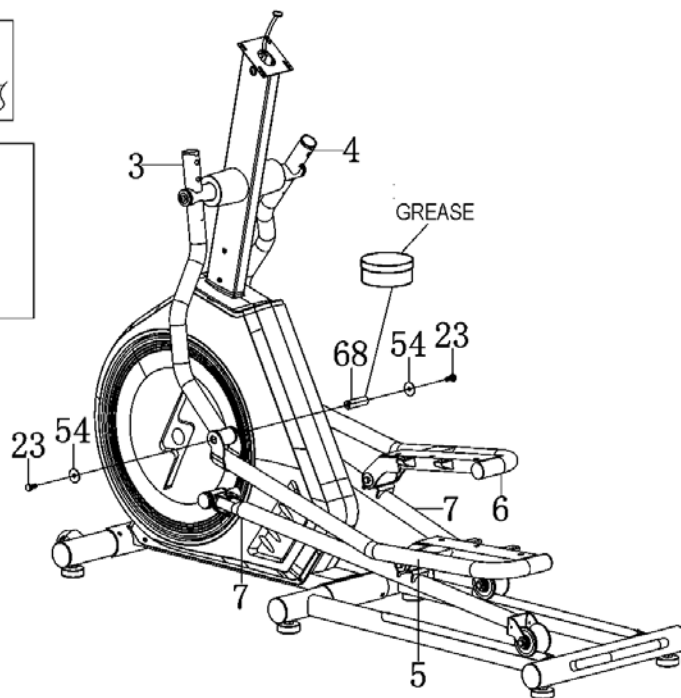
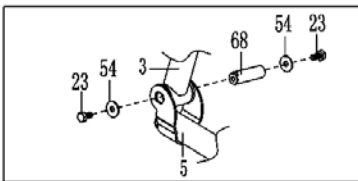
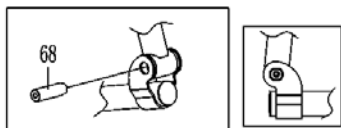

ASSEMBLY INSTRUCTIONS

STEP 7.

#31	X6
	

#14	X4
	

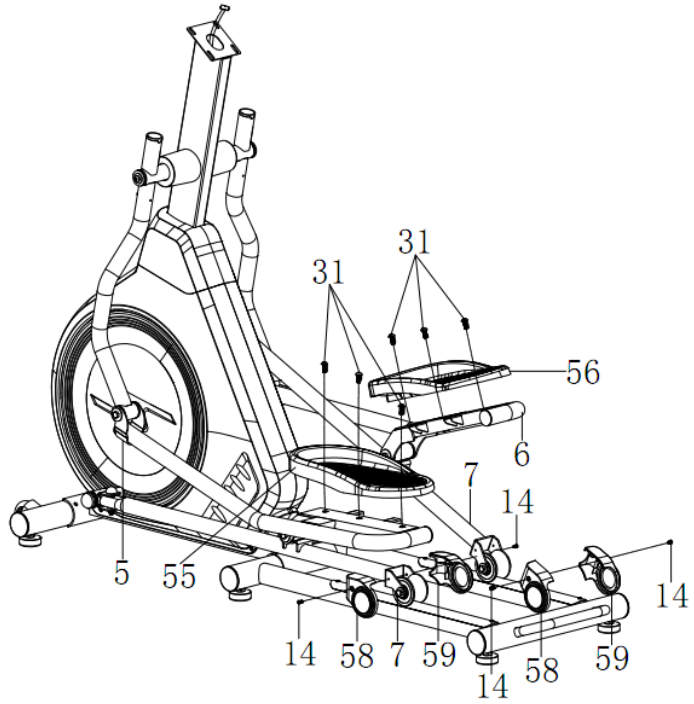

STEP 8.

#28	#20	#29	X4
			

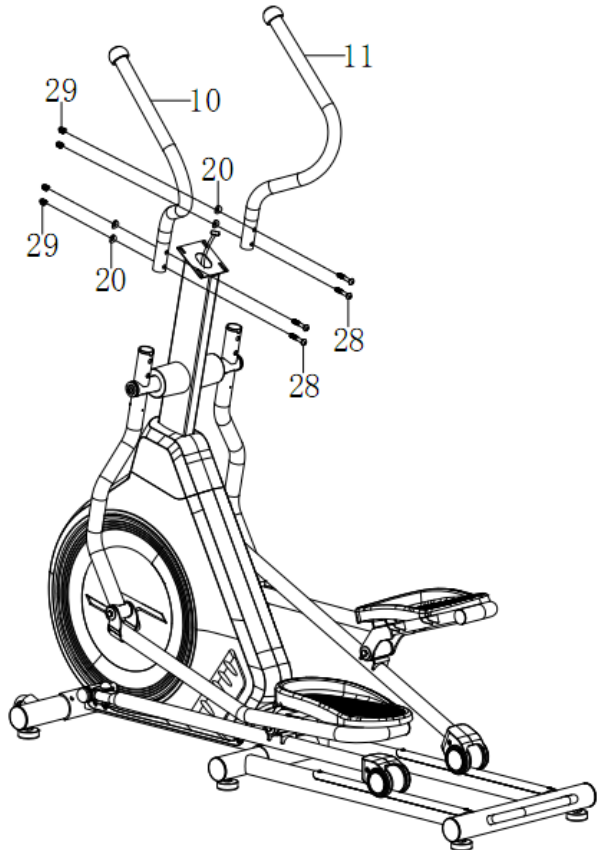

ASSEMBLY INSTRUCTIONS

STEP 9.

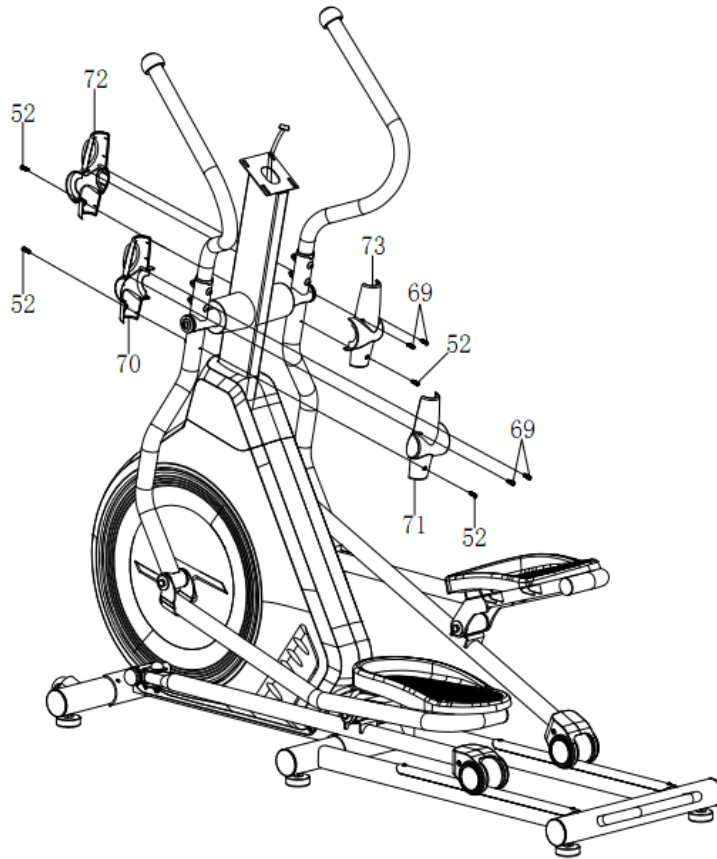
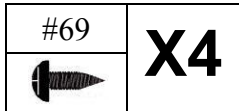
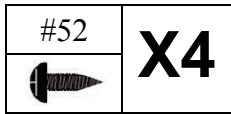

STEP 10.

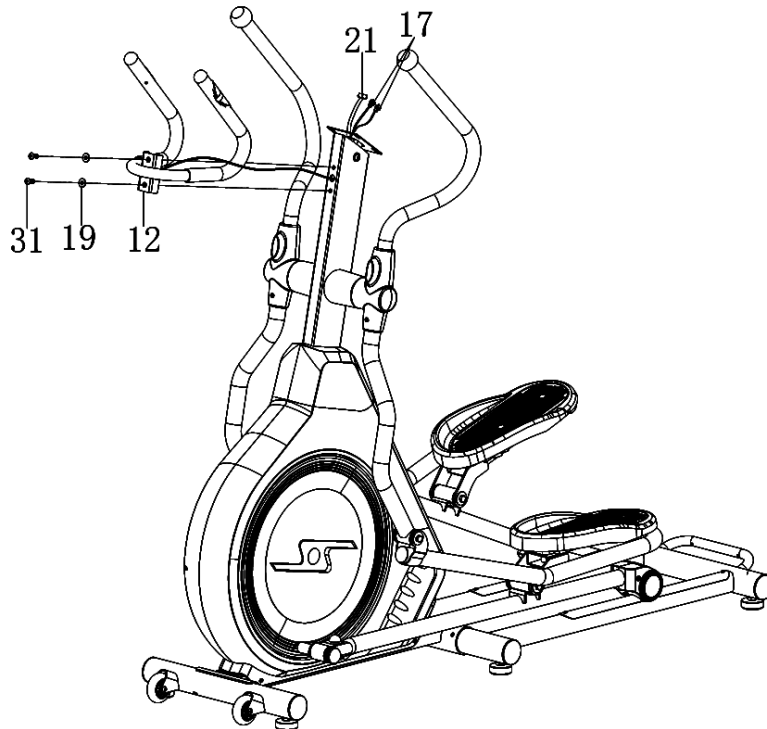
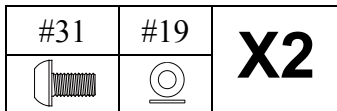

ASSEMBLY INSTRUCTIONS

STEP 11.

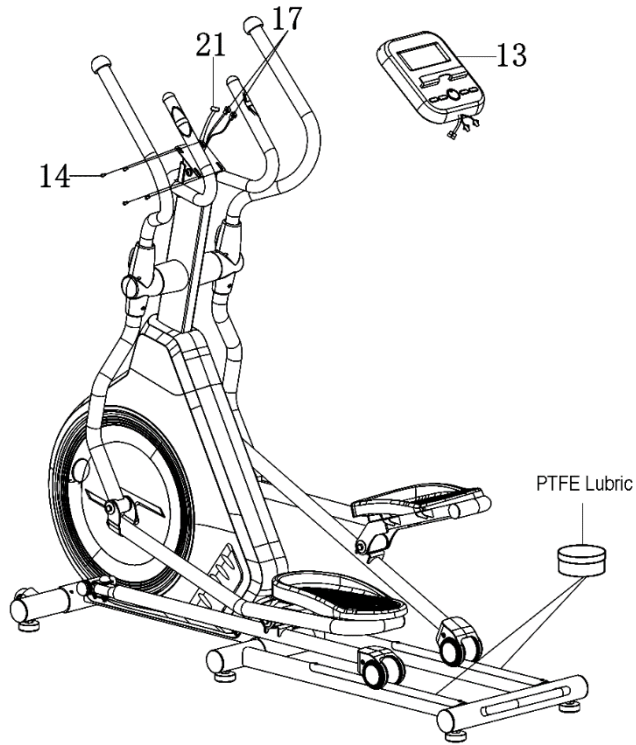
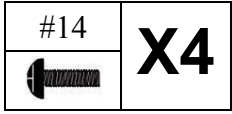

STEP 12.

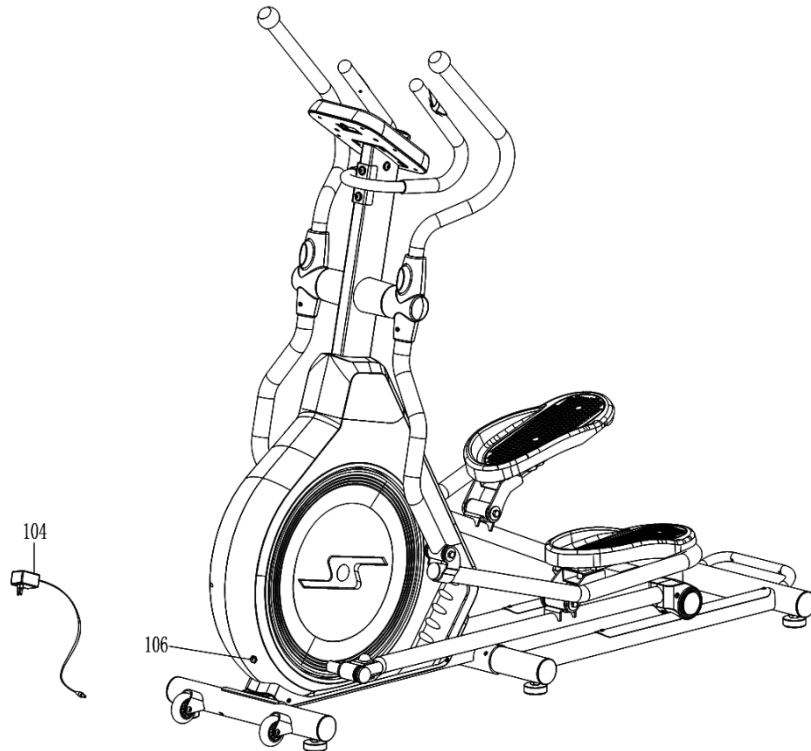

CONSOLE INSTRUCTIONS

DSC3639A



Key Functions

START/STOP(ST/SP): 1. Start & Pauses workouts.
2. Start body fat measurement.

DOWN: Decrease value of selected workout parameter: TIME, DISTANCE, etc. During the workout, it will decrease the resistance load.

UP: Increases value of selected workout parameter. During the workout, it will increase the resistance load.

MODE(ENTER): 1. To input desired value or workout mode.
2. Press to switch display form RPM to SPEED, ODO to DIST, WATT to Calories during workout.

TEST(PULSE \ RECOVERY): Press to enter into Recovery function when computer has the heart rate value. Recovery is Fitness Level 1-6 after 1 minute. F1 is the best, and F6 is the worst.

RESET (If have): To reset current setting. Holding key for 3 seconds will reset all function value to be zero.

BODY FAT (If have): Quickly select the BODY FAT program.

Workout Selection

After power-up using UP or DOWN keys to select then pressing ENTER to enter the desired mode.

Setting Workout Parameters

After selecting your desired program, you may pre-set several workout parameters for desired results.

WORKOUT PARAMETERS:

TIME / DISTANCE / CALORIES / AGE

Note: Some parameters are not adjustable in certain programs.

Once a program has been selected, pressing ENTER, will make "Time" parameter flash. Using UP OR DOWN KEY you may select desired time value. Press ENTER KEY to input value. Flashing prompt will move to the next parameter. Continue use of UP or DOWN KEY. Press START/STOP to start workout.

Program Operation Manual(P1)

Selecting "**Manual**" using UP OR DOWN KEY then pressing ENTER KEY. 1st parameter "Time" will flash so value can be adjusted using UP OR DOWN KEY. Press ENTER KEY to save value & move to next parameter to be adjusted.

Continue through all desired parameters, pressing START/STOP to start workout.

Note: One of workout parameters counts down to be zero, it will have bi sounds and stop the workout automatically. Press START KEY to continue the workout to reach the unfinished workout parameter.

TIME 0:00	SPEED 0.0	PULSE P
DIST KM 0.0		PROGRAM 1
CAL 0		LEVEL 6
		STOP

Pre-programs (P2-P7)

There are 6 program profiles ready for use.

Setting Parameters for Pre-programs

Selecting one of pre-programs using UP OR DOWN KEY then pressing ENTER KEY. 1st parameter "Time" will flash so value can be adjusted using UP OR DOWN KEY. Press ENTER KEY to save value & move to next parameter to be adjusted.

Continue through all desired parameters, pressing START/STOP to start workout.

Note: One of workout parameters counts down to be zero, it will have bi sounds and stop the workout automatically. Press START KEY to continue the workout to reach the unfinished workout parameter.

TIME 0:00	SPEED 0.0	PULSE P	TIME 0:00	SPEED 0.0	PULSE P	TIME 0:00	SPEED 0.0	PULSE P
DIST KM 0.0		PROGRAM 2	DIST KM 0.0		PROGRAM 3	DIST KM 0.0		PROGRAM 4
CAL 0		LEVEL 6	CAL 0		LEVEL 10	CAL 0		LEVEL 2
		STOP			STOP			STOP
TIME 0:00	SPEED 0.0	PULSE P	TIME 0:00	SPEED 0.0	PULSE P	TIME 0:00	SPEED 0.0	PULSE P
DIST KM 0.0		PROGRAM 5	DIST KM 0.0		PROGRAM 6	DIST KM 0.0		PROGRAM 7
CAL 0		LEVEL 2	CAL 0		LEVEL 4	CAL 0		LEVEL 4
		STOP			STOP			STOP

HEART RATE CONTROL Program(P8-P10)

There are 3 selections for target pulse:

P8- 55% TARGET H. R= 55% of (220-AGE)

P9- 75% TARGET H. R= 75% of (220-AGE)

P10- 90% TARGET H. R= 90% of (220-AGE)

Setting Parameters for HEART RATE CONTROL

Selecting "**One of Heart Rate Control Program.**" using UP OR DOWN KEY then pressing ENTER KEY. 1st parameter "Time" will flash so value can be adjusted using UP OR DOWN KEY. Press ENTER KEY to save value & move to next parameter to be adjusted.

Continue through all desired parameters, pressing START/STOP to start workout.

Note: If Pulse is above or below (± 5) the TARGET H.R, computer will adjust the resistance load automatically. It will check Every 10 seconds approx. I resistance load will increase or decrease.

One of workout parameters counts down to be zero, it will have bi sounds and stop the workout automatically. Press START/STOP KEY to continue the workout to reach unfinished workout parameter.

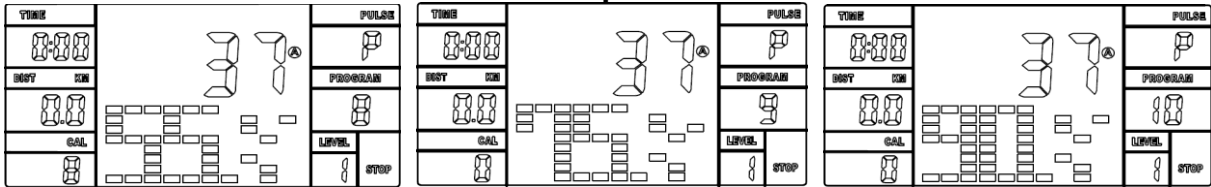

TARGET HEART RATE Program(P11)

Setting Parameters for TARGET H.R

Selecting “**TARGET H.R.**” using UP OR DOWN KEY then pressing ENTER KEY. 1st parameter “Time” will flash so value can be adjusted using UP OR DOWN KEY. Press ENTER KEY to save value & move to next parameter to be adjusted.

Continue through all desired parameters, pressing START/STOP to start workout.

Note: If Pulse is above or below (± 5) the set TARGET H.R, computer will adjust the resistance load automatically. It will check Every 10 seconds approx. I resistance load will increase or decrease.

One of workout parameters counts down to be zero, it will have bi sounds and stop the workout automatically. Press START/STOP to continue the workout to reach unfinished workout parameter.

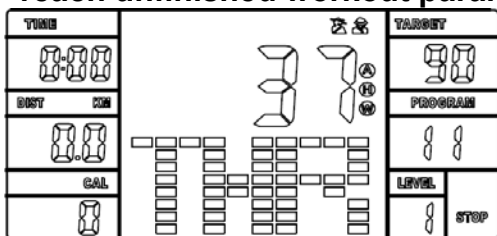

BODY FAT PROGRAM(P12)

Setting Data for Body Fat

Selecting “**BODY FAT Program**” using UP OR DOWN KEY then pressing ENTER. “Male” will flash so Gender can be adjusted using UP OR DOWN KEY, press ENTER to save gender & move to next data.

“175” of Height will flash so Height can be adjusted to use UP OR DOWN KEY, press ENTER KEY save value & move to next data.

“ 75 “of Weight will flash so Weight can be adjusted to use UP OR DOWN KEY, press ENTER KEY to save vale & move to next data.

“30” of Age will flash so Age can be adjusted using UP OR DOWN KEY, press ENTER to save value.

Press START/STOP to start measurement, please also grasp hand pulse grips.

After 15 seconds the display will show out Body Fat %, BMR, BMI & BODY TYPE.

NOTE: Body Types:

There are 9 body types divided according to the FAT% calculated. Type 1 is from 5% to 9%. Type 2 is from 10% to 14%. Type 3 is from 15% to 19%. Type 4 is from 20% to 24%. Type 5 is from 25% to 29%. Type 6 is from 30% to 34%. Type 7 is from 35% to 39%. Type 8 is from 40% to 44%. Type 9 is from 45% to 50%.

BMR: Basal Metabolism Ratio

BMI: Body Mass Index

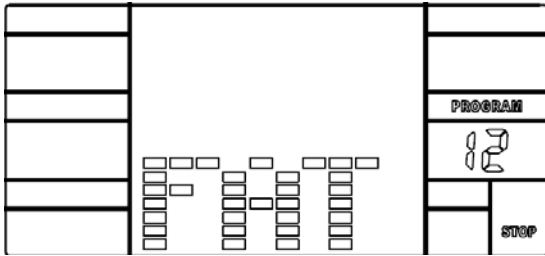

Connect the instrument power supply

Plug one end of the power adapter into the ac power socket and the output of the other end into the power interface of the meter. At this time, the meter will emit a "BEEP" sound for 1 second, and the instrument will be fully displayed into the initial state of the meter.

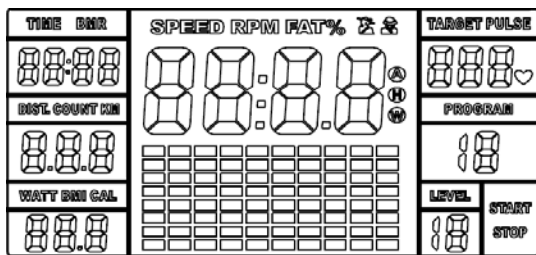

Li alarm prompt

- 1、 Instrument display ERROR1 indicates that the connection wire of the motor is not in good contact or the motor is damaged
- 2、 Instrument display ERROR2 indicates no hand - held heart rate signal input during body fat test

Power supply: power adapter

Input A C (according to national grid standards)

MAINTENANCE

Cleaning

The elliptical trainer can be cleaned with a soft cloth and mild detergent. Do not use abrasives or solvents on plastic parts. Please wipe your perspiration off the elliptical trainer after each use. Be careful not get excessive moisture on the computer display panel as this might cause an electrical hazard or electronics to fail. Please keep the elliptical trainer, specially, the computer console, out of direct sunlight to prevent screen damage. Please inspect all assembly bolts and pedals on the machine for proper tightness every week.

Storage

Store the elliptical trainer in a clean and dry environment away from children.

TROUBLE SHOOTING

PROBLEM	SOLUTION
The elliptical trainer wobbles when in use.	Turn the rear stabilizer end cap on the rear stabilizer as needed to level the elliptical trainer.
There is no display on the computer console.	<ol style="list-style-type: none">1. Remove the computer console and verify the wires that come from the computer console are properly connected to the wires that come from the front post.2. Check if the batteries are correctly positioned and battery springs are in proper contact with batteries.3. The batteries in the computer console may be dead. Change to new batteries.
There is no heart rate reading or heart rate reading is erratic / inconsistent.	<ol style="list-style-type: none">1. Make sure that the wire connections for the hand pulse sensors are secure.2. To ensure the pulse readout is more precise, please always hold on to the handlebar grip sensors with two hands instead of just with one hand only when you try to test your heart rate figures.3. Gripping the hand pulse sensors too tight. Try to maintain moderate pressure while holding onto the hand pulse sensors.
The elliptical trainer makes a squeaking noise when in use.	The bolts may be loose on the elliptical trainer, please inspect the bolts and tighten the loose bolts.

EXPLODED DIAGRAM

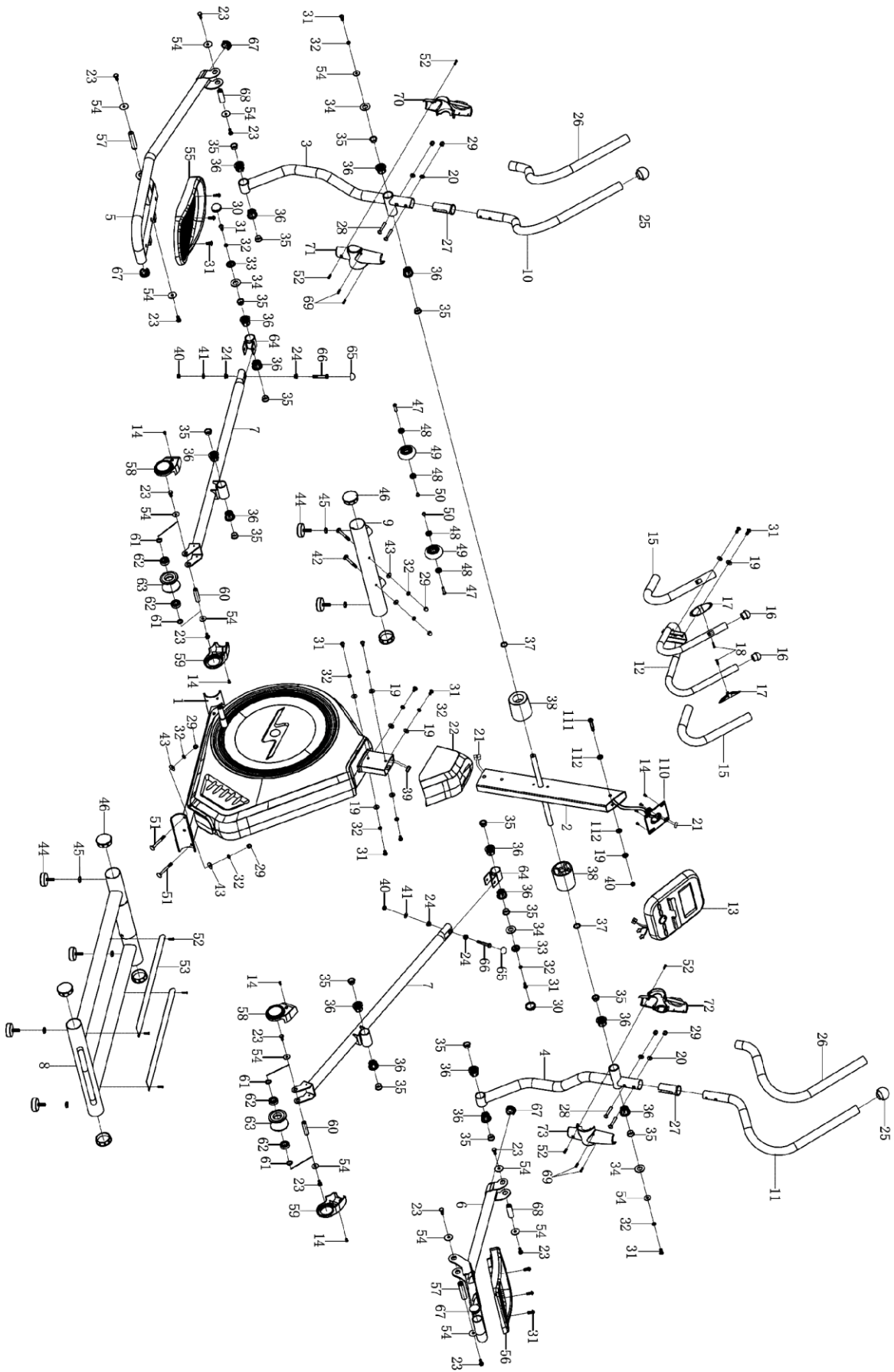

EXPLODED DIAGRAM

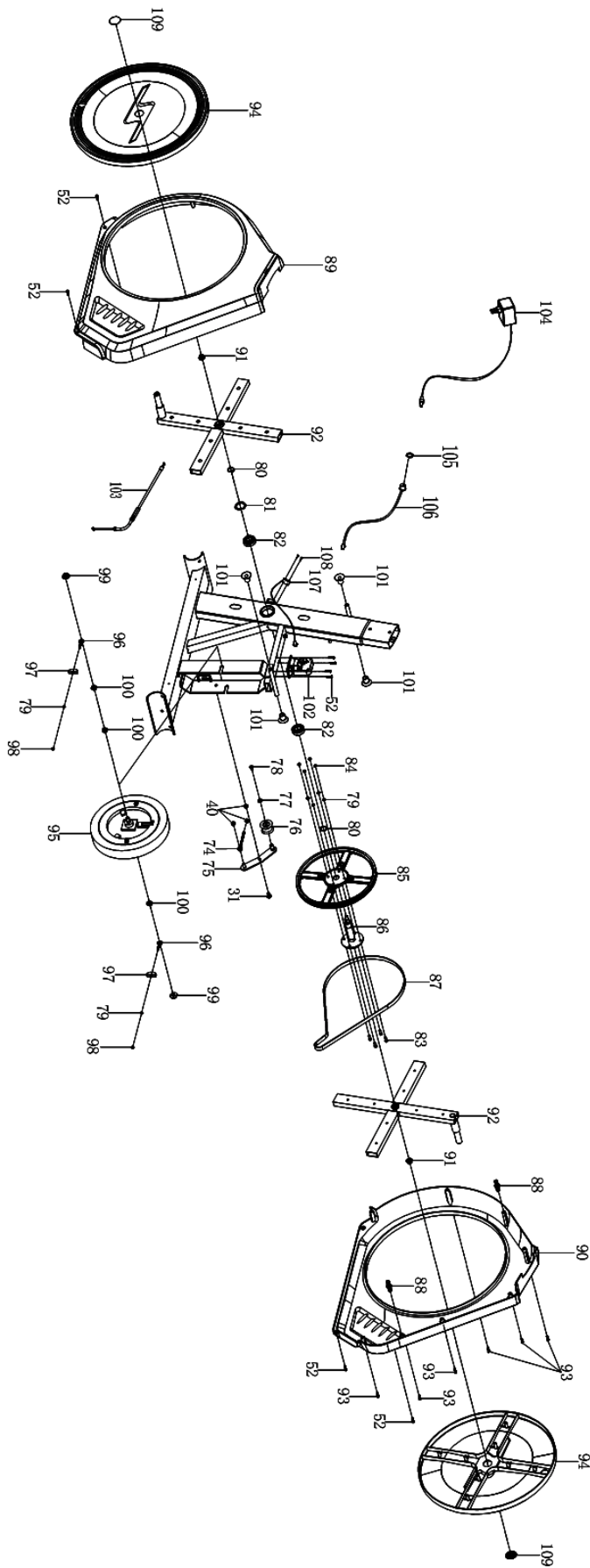

PART LIST

No.	Description	Qty
001	Main Frame	1
002	Front Post	1
003	Left Swing Tube	1
004	Right Swing Tube	1
005	Left Foot Tube	1
006	Right Foot Tube	1
007(L/R)	Drive Tube	2
008	Rear Main Frame	1
009	Front Stabilized	1
010	Left Handrail Arm	1
011	Right Handrail Arm	1
012	Handlebar	1
013	Console	1
014	Bolt M5*10	8
015	Handlebar Foam Grip Ø24* Ø31*510	2
016	End Cap for Handlebar Ø25*1.5	2
017	Hand Pulse Sensor with Wire=750mm	2
018	Self- tapping screw ST4.2*20	2
019	Big Washer Ø8* Ø20*2.0	9
020	Arc Washer Ø8* Ø16*1.5	4
021	Extension Sensor Wire=800mm	1
022	Front Post Cover	1
023	Bolt M8*16	12
024	Connecting rod small bushing Ø18* Ø8*10	4
025	End Cap for Handlebar Ø50	2
026	Handlebar Foam Grip Ø31*Ø37*700	2
027	Bushing	2
028	Bolt M8*49	4
029	Cap Nut M8	8
030	Cap Nut Ø38	2
031	Bolt M8*20	19
032	Spring Washer Ø8	14
033	Washer Ø8* Ø33*2.0	2
034	Big Washer Ø19* Ø38*3.0	4
035	POM Bushing Φ27*11	16
036	Plastic Bushing Ø38x24	16
037	Wave Spring Washer Ø19* Ø29*0.5	2

PART LIST

No.	Description	Qty
038	Shaft Sleeve	2
039	Sensor Wire L=600mm	1
040	Nut M8	6
041	Washers Ø8* Ø16*1.5	2
042	Bolt M8*75	2
043	Big Wave Washer Ø8* Ø20*2.0	4
044	Foot Pad M10*20	6
045	Nut M10	6
046	Circular Tube Plug Ø60*1.5	6
047	Bolt Ø8*32	2
048	Bearing608	4
049	Roller wheel Ø71*24	2
050	Bolt M6*12	2
051	Bolt M8*80	2
052	Self-tapping self-drilling screw ST4.2*20	12
053	Aluminum Bar 530*42*2.1	2
054	Big Washers Ø8* Ø25*2.0	14
055	Left Foot Pedal	1
056	Right foot Pedal	1
057	Pedal connecting shaft Ø19* 82.5	2
058	Left Roller cover	2
059	Right Roller cover	2
060	Roller connecting shaft Ø15* 63.8	2
061	Roller Spacing Ø22* 3.1	4
062	Bearing 6202	4
063	Pulley	2
064	Foot Turn Tube Assembly	2
065	Nut Cap S13	2
066	Bolt M8*50	2
067	End Cap Ø38*1.8	4
068	Connecting rod shaft Ø19*61	2
069	Self- tapping screw ST2.9*16	4
070	Left Swing Tube Cover-A	1
071	Left Swing Tube Cover-B	1
072	Right Swing Tube Cover-A	1
073	Right Swing Tube Cover-B	1
074	Eyebolt M8*65	1

PART LIST

No.	Description	Qty
075	Idle Wheel Bracket	1
076	Press Wheel	1
077	Washer Ø12* Ø6*1.0	1
078	Bolt M6*12	1
079	Spring Washer Ø6	6
080	Circlip Ø20*1.0	2
081	Wave Washer Ø20* Ø24*0.3	1
082	Bearing 6004-2Z	2
083	Bolt M6*15	4
084	Nut M6	4
085	Belt Pulley	1
086	Straight Spindle Assembly	1
087	Belt	1
088	Plastic BoltΦ8x32	2
089	Left Cain Cover	1
090	Right Cain Cover	1
091	Nut M10x1.25	2
092	Turntable Assembly	2
093	Screw ST4.2*25	6
094	Turntable	2
095	Flywheel	1
096	Eyebolt M6*36	2
097	U-bracket 31*30*δ1.0	2
098	Bolt M6 S10	2
099	Nut M10*1.0*6	2
100	Nut M10*1	3
101	Limit File Piece	4
102	Motor L=300	1
103	Motor is disconnected L=400	1
104	AC adaptor	1
105	Hexagonal flat nut for connecting wire	1
106	Voltage regulator terminal	1
107	Sensor with Wire L=750mm	1
108	Screw ST2.9*12	2
109	End Cup for Turntable	2
110	Console support	1
111	Bolt M8x60	1

PART LIST

No.	Description	Qty
112	PVC washer ϕ 10* ϕ 20*1.5	2

BODYWORX



PROGRAMMABLE ELIPTICAL

Model No: EFX580

To register your warranty, please go to

www.gpisports.com.au

DISTRIBUTED EXCLUSIVELY BY

GPI Sports & Fitness

275 Wellington Road

Mulgrave, VIC, 3170

Australia
